

smartstuff™

furniture for kids.

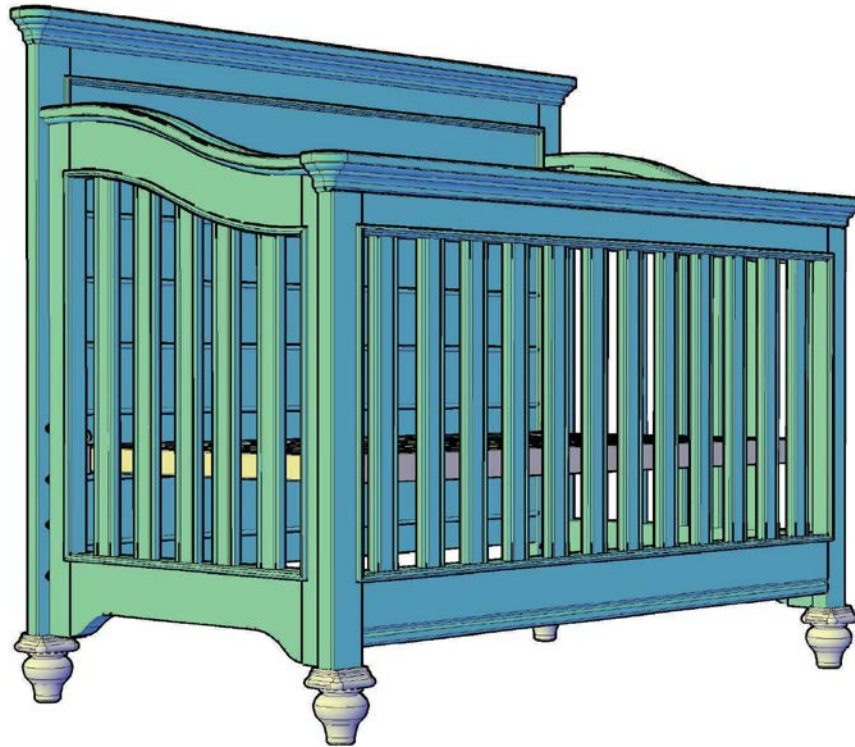

Model Numbers:

1311310, 131A310, 1312310, 136A310, 2391310, 330A310, 434A310, 437A310, 437B310

Crib Assembly Instructions

Thank you for your purchase of a smartcrib. smartcribs are designed, engineered and certified to meet the safety guidelines of the Consumer Product Safety Commission as well as ASTM International standards. Keep these instructions for future reference.



WARNING: FAILURE TO FOLLOW THESE ASSEMBLY INSTRUCTIONS
COULD RESULT IN SERIOUS INJURY OR DEATH.

- When child is able to pull to a standing position, set the mattress to the lowest position and remove bumper pads, large toys and other objects that could serve as steps for climbing out.
- When a child is able to climb out or reaches the height of 35 in. (90 cm), the crib shall no longer be used.
- **DO NOT** place a crib near a window where cords from blinds or drapes may strangle a child.
- To reduce the risk of SIDS, pediatricians recommend healthy infants be placed on their backs to sleep, unless otherwise advised by your physician.
- To help prevent strangulation tighten all fasteners. A child can trap parts of the body or clothing on loose fasteners.
- **Strings can cause strangulation!** Do not place items with a string around a child's neck, such as hood strings or pacifier cords. Do not suspend strings over a crib or attach strings to toys.
- Before each usage or assembly, inspect crib for damaged hardware, loose joints, missing parts or sharp edges. **DO NOT** use crib if any parts are missing or broken. Contact your dealer or Universal Furniture at (877) 804-5536 for replacement parts and instructional literature if needed or email us at rporders@samsonmktg.com.
- **DO NOT** substitute parts. Use only bolts that are supplied by the manufacturer or parts of comparable quality and equal dimensions. Do not allow ends of bolts or sharp edges to be exposed.
- Follow warnings on all products in a crib.
- If refinishing, use a non-toxic finish specified for children's products.
- Infants can suffocate on soft bedding. Never add a pillow, comforter or padding. Never place additional padding under an infant.
- Infants can suffocate in gaps between crib sides and a mattress that is too small.
- Never use plastic shipping bags or other plastic film as mattress covers because they can cause suffocation.
- Do not allow child to crawl or play underneath crib.
- Use caution when a vaporizer is in use. Always aim the vapor steam away from the crib as well as away from any other wood furniture item.
- The crib must be fully assembled prior to use.
- Read all instructions before assembling crib. **KEEP INSTRUCTIONS FOR FUTURE USE.**
- **CAUTION:** Any mattress used in this crib must be at least 27-1/4" by 51-5/8" with a thickness of no less than 4 inches and not exceeding 6 inches.

When converting to a Toddler Bed:

- Never use bed with children under 15 months of age.
- The maximum weight of the intended user shall not be greater than 50 lbs. (22.7kg).

smartcrib Assembly

NOTE: Read and understand all instructions before assembling this crib. Keep these instructions for future reference.

This crib conforms to the ASTM International and the CPSC-Consumer Product Safety Commission guidelines for product safety. Please adhere to the guidelines in this booklet for assembly, use and maintenance.

Please note the recommendations below:

- **Attached** to the mattress platform is a sleeve to safely store these instructions. Do not remove this sleeve and return these instructions to the sleeve for future reference.
- Two people required for safe assembly. Do not **attempt** to assemble with one person as the crib may become damaged if not handled properly.
- Assemble the crib in the space where it is intended to be used.
- Use only the hardware and tools supplied to assemble the crib.
- Do not use power tools to assemble the crib.
- Do not substitute any part. If any part is missing, contact Universal Furniture at (877) 804-5536 immediately for replacement parts or hardware.
- Do not assemble if any part is broken. Contact Universal or the retailer immediately.
- Make sure all fasteners are tight.
- Please take your time and read the instructions carefully.

Tools required for assembly:

- Allen key that is provided.

Identify the individual parts of the crib for reference in assembling your bed. While the illustrations in this manual are generic, the assembly method is the same for the model numbers listed on the front page.



Left Crib End

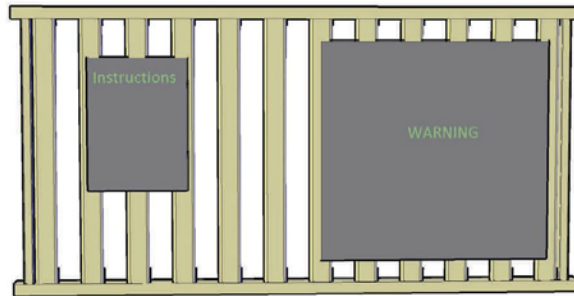

Mattress Platform

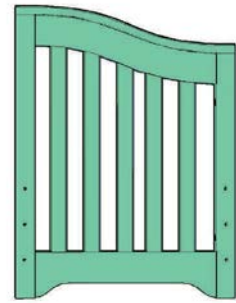

Right Crib End

Crib Headboard

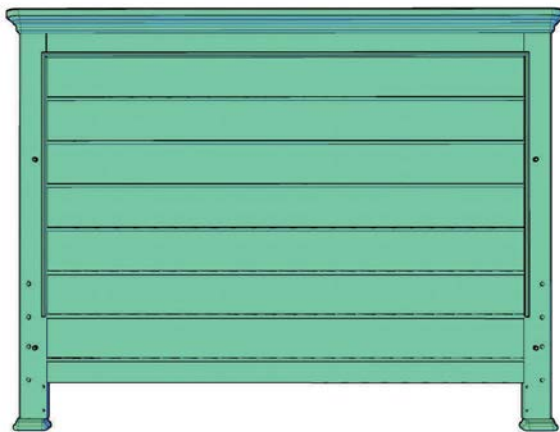

Crib Footboard

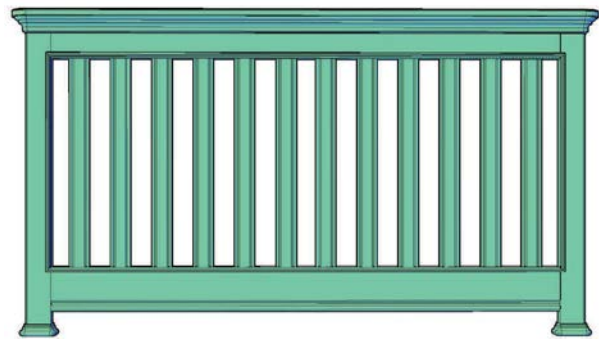

4 Headboard and Footboard Feet

Identifying the hardware to be used for assembly of the Crib

(16) lock washers



(16) flat washers



(4) Allen bolts 38mm

M6 thread **BOLT (A)**

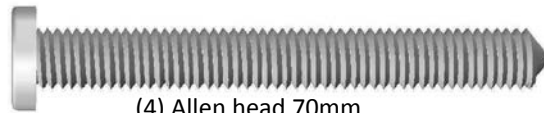

(4) Allen head 70mm

M6 thread **BOLT (B)**



(2) Allen head cover bolts

M6 thread **BOLT (D)**



(8) Allen head 16mm M6

thread **BOLT (C)**

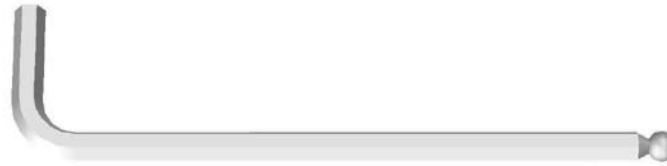

(2) Allen keys

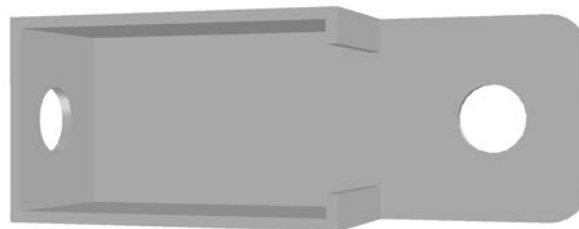

(4) Mattress support brackets

STEP 1

Assemble Mattress Platform Support Brackets

- Two people required for safe assembly.
- Assemble the crib in the space where it is intended to be used.
- Use only the hardware and tools supplied to assemble the crib.
- Do not use power tools to assemble the crib.
- Do not substitute any part.
- Do not assemble if any part is broken.
- If any part is broken or missing contact Universal Furniture at (877) 804-5536 or the retailer immediately for a replacement part.

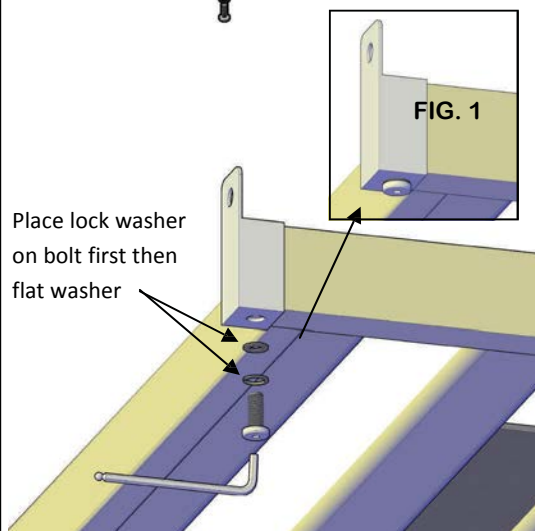
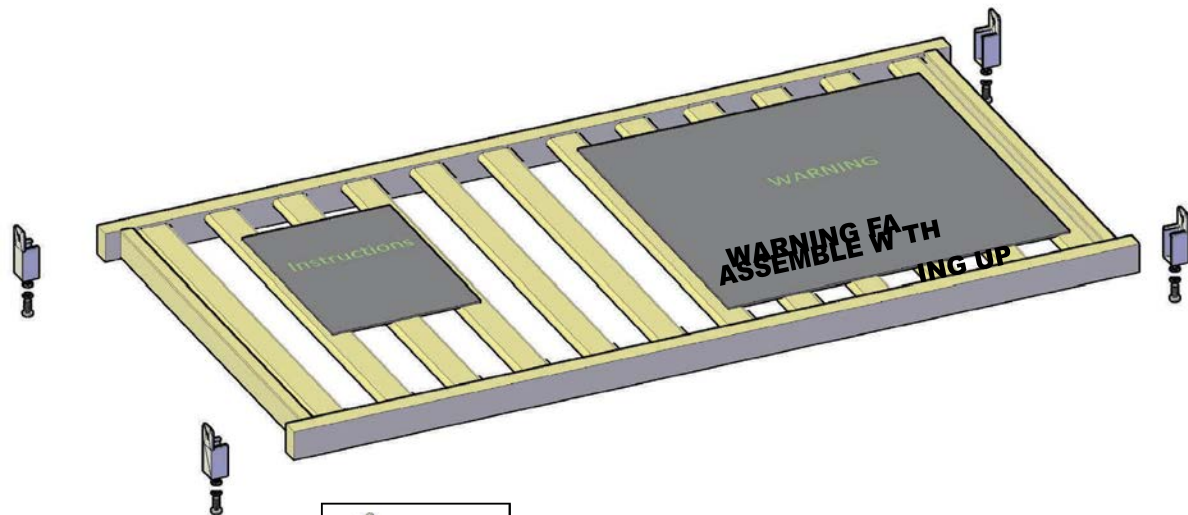

Place lock washer on bolt first then flat washer

- Use **bolt C**, **flat washer** and **lock washer** to attach the 4 **brackets** to the mattress platform.
- The warning label and the instruction holder must be facing up so that it is readable.
- Place the lock washer on the bolt first, followed by the flat washer.
- Using the supplied Allen key, tighten the bolt as shown to attach the bracket.
- When assembly is complete, the four corners of the mattress platform will look like Fig. 1.

smartCRIBS

STEP 2

Assemble the Headboard to the Crib Ends

The crib has a feature that allows for a HIGH or LOW set up. The screw on feet can be attached or can be left off depending on the comfort of the parent or guardian to access the child. At this stage, determine if the higher position is desirable or the lower. At any point in the future, the feet can be added back or removed depending on the height desired. NOTE: the foot set up for the headboard and footboard attachment must be the same to keep mattress level.



Attach the feet by screwing them in clockwise from the bottom. NOTE: the base feet are removable if a lower crib height is desired. Make sure that if the feet are not used on the headboard they are not used on the footboard to keep the mattress platform level.

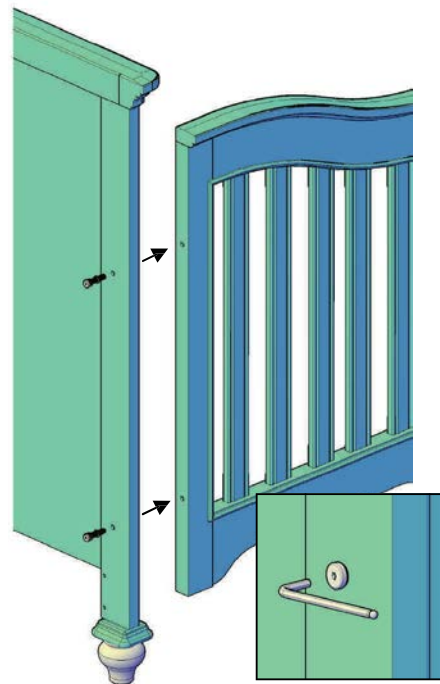
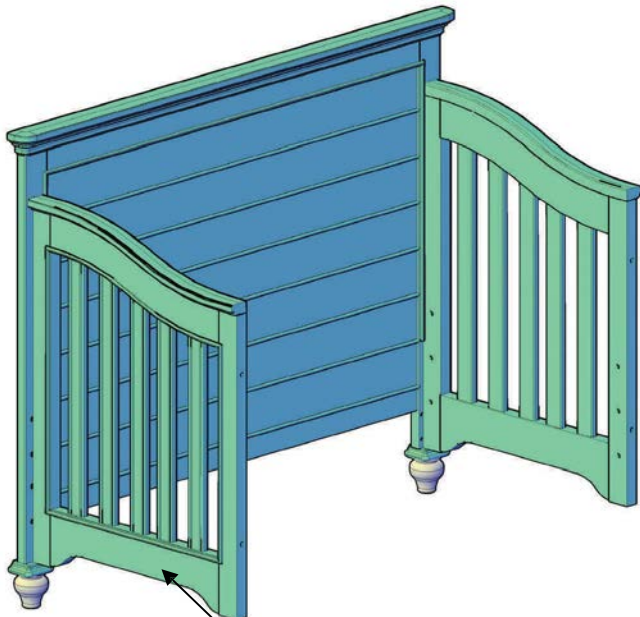

FIG. 2



Warning labels on crib ends should be facing outward.

- Slide a lock washer over BOLT A then slide a flat washer over BOLT A.
- Align a crib end with the headboard making sure the mattress platform holes are on the inside of the crib.
- From the back of the Headboard, attach the bolts to the crib end with the supplied Allen key and tighten (see FIG. 2).
- Repeat the process for the other crib end.

smartCRIBS

STEP 3

Assemble the Mattress Platform

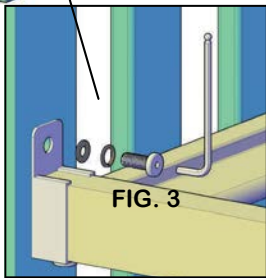
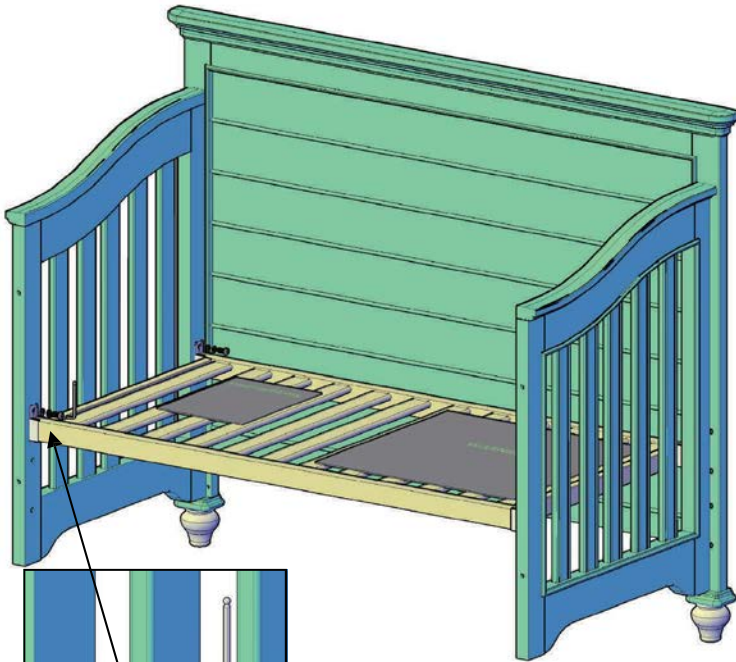

- This crib has three mattress heights. Install the mattress platform at the highest level for infants. Once the child starts to pull up to a standing position, lower the mattress platform to the lowest position.
- Two people required to align the support brackets to the desired height location.
- Slide the lock washer first over BOLT C then slide the flat washer on the bolt (see FIG. 3)
- Using the supplied Allen key, attach the brackets at the four corners make sure the instructions and warnings are facing up.
- Tighten the bolts.

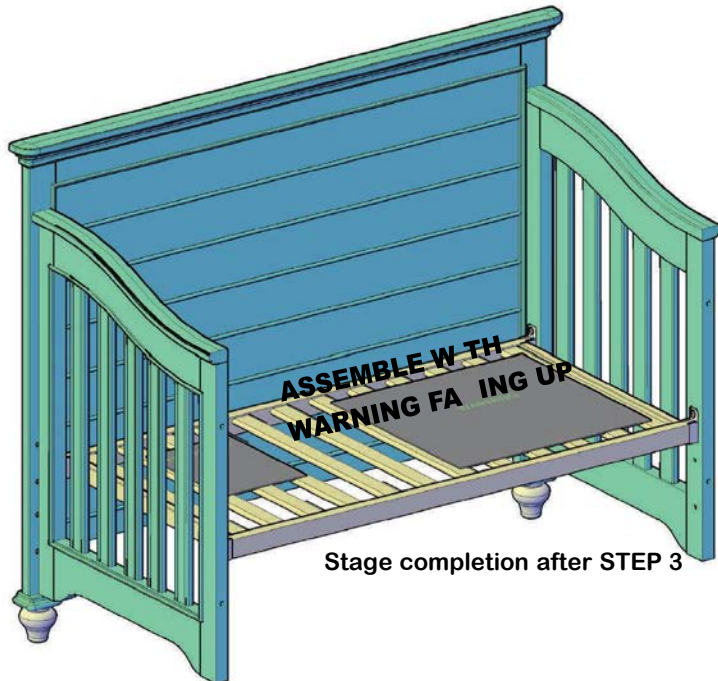

STEP 4

Assemble the Footboard

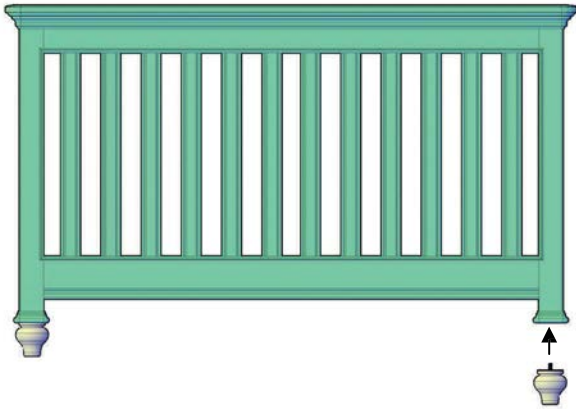

Attach the feet by screwing them in clockwise from the bottom.
NOTE: the base feet are removable if a lower crib height is desired. Make sure that if the feet are not used on the headboard they are not used on the footboard to keep the mattress platform level.

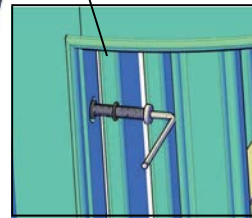

FIG.4



- Slide a lock washer and then a flat washer over BOLT B (see FIG. 4).
- Align the footboard with the crib end assemblies. Use BOLT B to attach the footboard by loosely threading the 4 bolts into the inserts in the footboard.
- After all four bolts have been set, securely tighten each bolt with the provided Allen key as shown in (FIG. 4).
- Your assembled crib should look like the illustration at the left.

STEP 5

Final Step: Checklist



- Inspect the crib to make certain that all bolts are tight and secure and no hardware is missing. If you find you have missing hardware, contact Universal Furniture immediately and **DO NOT** use the crib until the hardware arrives.
- **DO NOT** place the crib near a window where the child may have access to window coverings, cords or draperies as these have been proven to be strangulation hazards.
- Keep the instructions in the holder provided for safe keeping and future reference. Always keep the instructions with the crib.
- Follow all the warnings on the use of this crib and for all products used in the crib.
- Never use plastic shipping bags or other plastic film as mattress covers because they can cause suffocation.
- Infants can suffocate in gaps between crib sides and a mattress that is too small. Use the proper size mattress.
- **CAUTION:** Any mattress used with this crib must be at least 27-1/4" (69cm) by 51-5/8" (131cm) with a thickness of no less than 4 inches (10cm) and not to exceed 6 inches (15cm).

Care and Maintenance Instructions

Cleaning:

Mix a mild solution of gentle dishwashing liquid and water. Using a soft cloth that is dampened lightly with clear water, apply the solution to the crib surface. Use a separate cloth dampened lightly with clear water to remove any residue left by the cleaning solution. Dry the surface with a soft clean cloth. DO NOT use abrasive cleaners, ammonia, steel wool, scouring pads or other household cleaners as they may leave behind residue that could be harmful to children or damage the finish.

Storage:

The instruction sheet sleeve is permanently attached to the crib mattress platform. Do not remove the sleeve or the Warning card attached to the platform. Place the instructions back in the bag. Properly label any unused hardware and store in a safe place for future use. Do not store the unused hardware in the instruction sleeve as it could present a hazard or cause damage to the crib mattress. If the crib is stored for future use, place the crib in a temperature controlled environment where humidity is not a concern. High temperature and high humidity can damage wood products.

Maintenance:

1. Periodically check all bolts and fasteners to make sure they are tight and secure.
2. If for any reason a part is missing, DO NOT substitute parts. Contact Universal Furniture at (877) 804-5536 or the retailer where the crib was purchased. Use the instructions for identification of parts when ordering replacement parts.
3. The crib allows for 3 mattress heights. Move the crib to the lowest position when the child can pull up to a standing position. When the child reaches a height of 35" or can climb out of the crib, you should place the child in a youth, toddler or regular bed.
4. Save these instructions in the attached sleeve on the mattress platform. Do not remove the sleeve from the platform. These instructions will aid in reassembly if the crib is moved and needs to be reassembled.

Lowering the Mattress Platform

- Two people required to perform this task.
- Remove the mattress from the crib.
- Loosen the 4 bolts attaching the footboard and make sure to retain all the washers and bolts in a secure location.
- Remove the footboard and place in a secure location.
- Loosen the 4 bolts attaching the mattress and place the platform in the next desired height location.
- Go back to Step 3, 4 and 5 on pages 8, 9 and 10 to reassemble the crib for use.

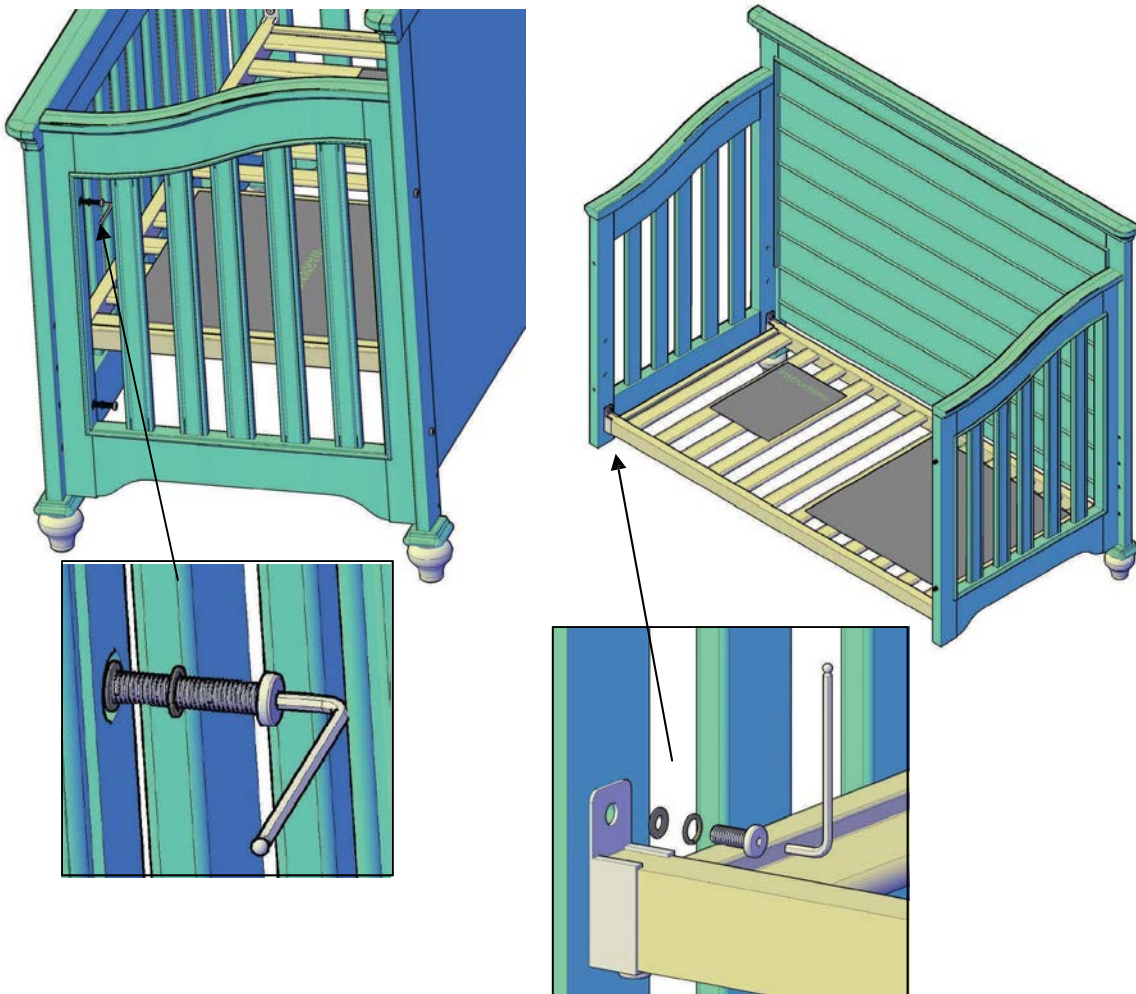

Options and Accessories

Toddler bed conversion kits can be purchased from an authorized smartstuff retailer. Consult our dealer locator at www.smartstufffurniture.com to find the dealer nearest you.

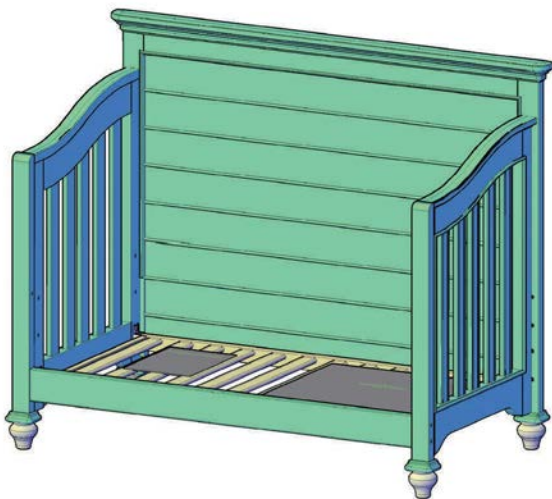
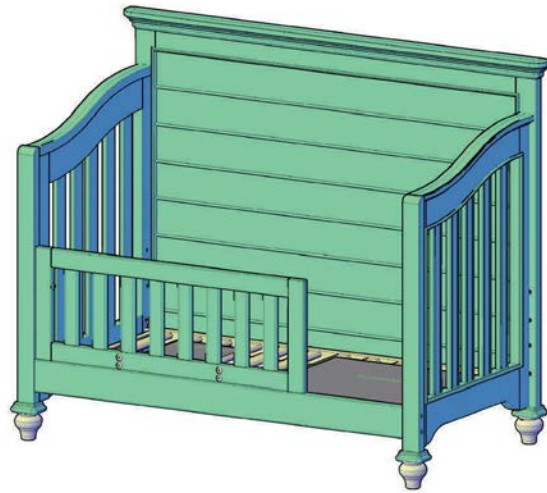

Toddler bed conversion kits can also be used to create a day bed. Consult our dealer locator at www.smartstufffurniture.com to find the dealer nearest you.

Conversion to a full size bed can be made with the purchase of bed rails and a slat roll from an authorized smartstuff retailer.

Consult our dealer locator at www.smartstufffurniture.com to find the dealer nearest you.

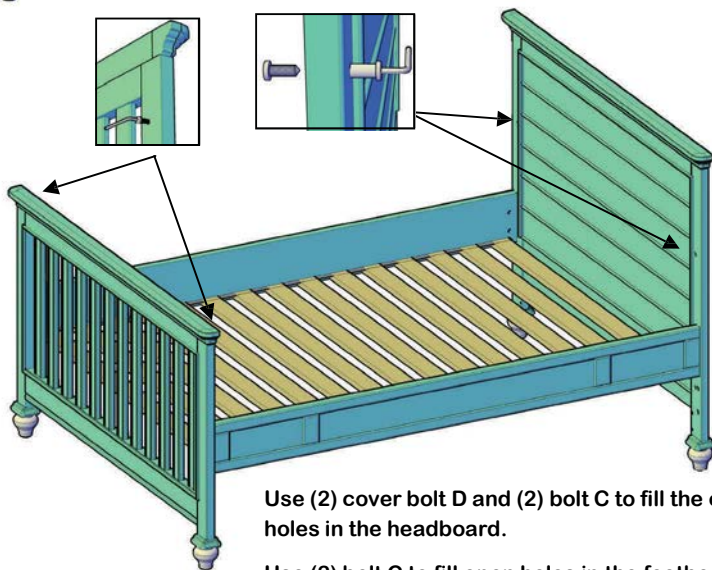

Use (2) cover bolt D and (2) bolt C to fill the open holes in the headboard.

Use (2) bolt C to fill open holes in the footboard.

NOTE: Bolt C is the same bolt used to attach the mattress platform.

smartCRIBS

smartstuff™

furniture for kids.

smartstuff is a registered product
manufactured and marketed by
UNIVERSAL FURNITURE INTERNATIONAL, INC

2575 Penny Road High Point,

NC 27265

www.universalfurniture.com

(877) 804-5536