

UNIVERSAL[®]

FURNITURE

INSTRUCTION SHEET

988/989-829

Storage Cocktail Table

Thank you for purchasing this quality product. Be sure to check all packing material carefully for small parts that may have come loose inside the carton during shipment.

Caution: (1) These parts are cumbersome and heavy. This product can best be assembled with the assistance of one or more persons in order to prevent personal injury and to insure parts are not damaged during the assembly process. If dirty, clean finished parts with mild dishwashing liquid and water solution applied on damp cloth. Cloth should not be excessively wet. Polish finish with soft cloth and an industry recognized furniture polish.

(2) To prevent damage to your floor or carpet, please check the bottom of each piece of furniture for stain residue and rough surfaces and also check for staples or nails left after removing the packaging material. The manufacturer will not be held responsible if preventative steps are not taken prior to installation.

(3) Unpack and dispose of all packing material but be careful not to throw away any assembly parts or hardware. Read the instruction sheet and parts list carefully. Remove all staples and screws used for packaging carefully using pliers and or screwdrivers to prevent injury and scratching or damaging flooring.

(4) During normal use everyday, screws, bolts, nuts and wooden plugs may loosen up. They should be periodically inspected and re-tightened to prevent damage to the furniture and (or) personal property or cause injury. Always check to be sure all hardware on this list and the above mentioned components is attached to the furniture properly and kept tightened at all times.

PARTS LIST:

#	Description	Qty.	#	Description	Qty.
A	Table Top	1 pc	B	Shelf	1 pc
C	Corner Leg	4 pcs	D	Center Leg	2 pcs
E	Basket	2 pcs	F	Hardware Pack	1 bag

Assembly Procedure: (Please follow the sketches below.)

Step 1: Unpack, inspect, and read assembly instruction carefully. Lay out the parts and hardware. Make sure the quantity of each is correct.

Step 2: Put the table top (A) face down on a soft and smooth surface to avoid damage or being scratched. Attach two corner legs (C) to table top (A) with long bolts (2), lock washers (4) and flat washers (6) by wrench (8). Attach shelf (B) to legs (C) with short bolts (1), lock washers (3), flat washers (5) and metal brackets (7) by wrench (8).







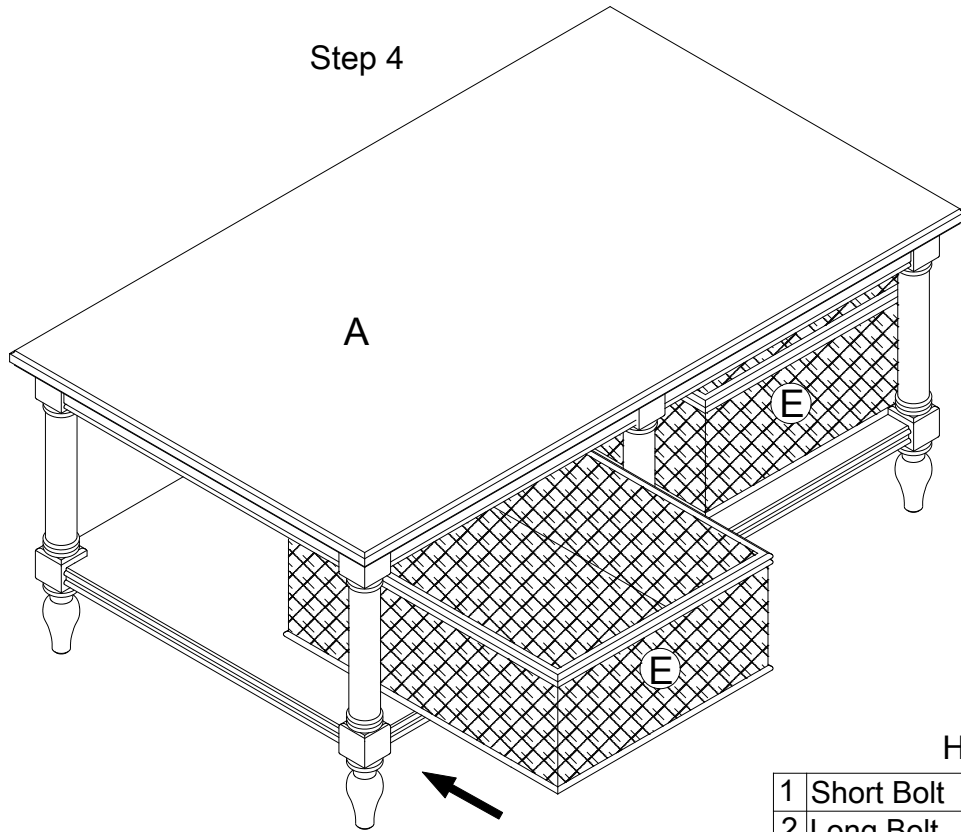
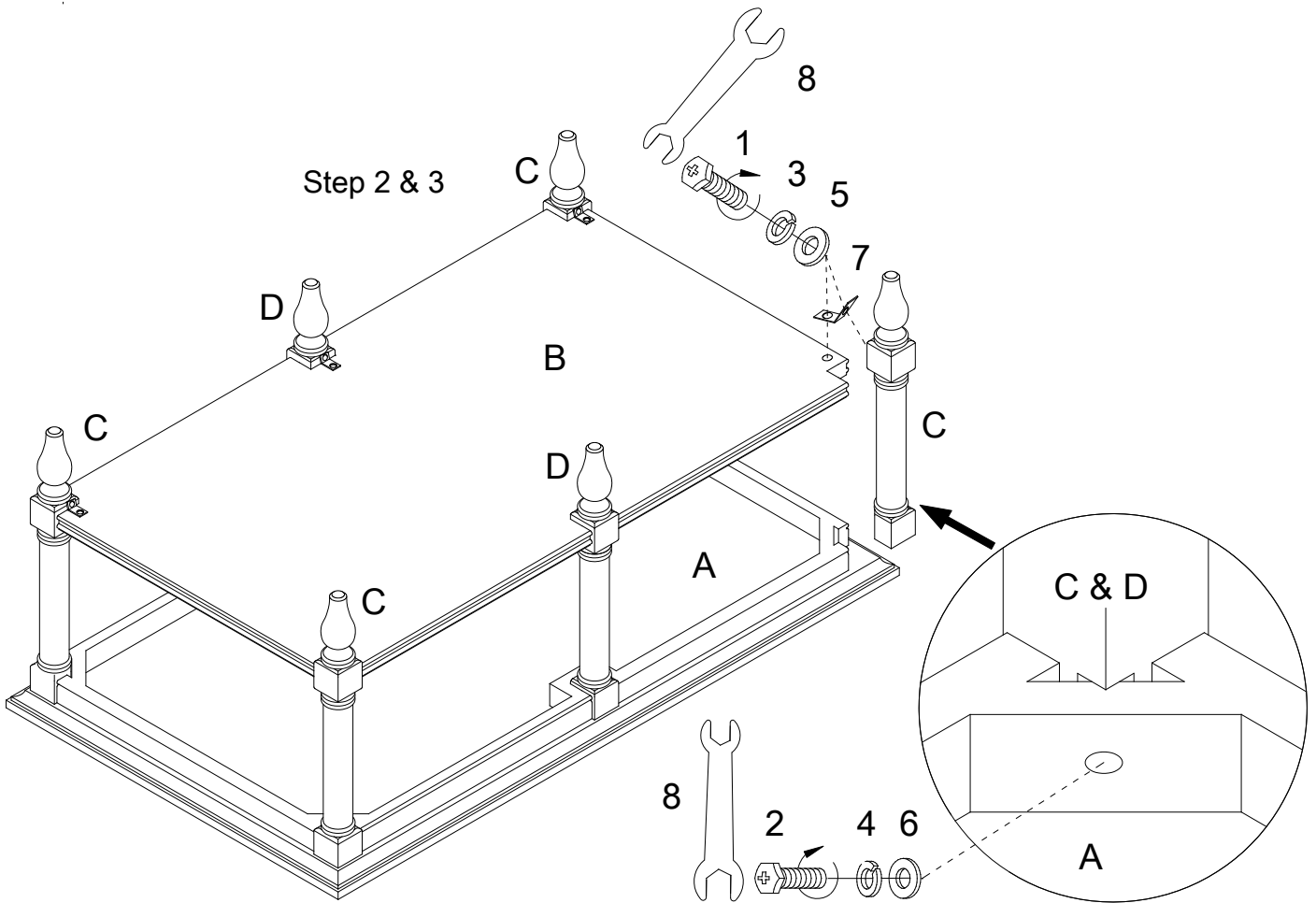

Step 3: Attach the other corner legs (C) and center legs (D) to table top (A) with long bolts (2), lock washers (4) and flat washers (6). Attach the corner leg (C) and center legs (D) to shelf (B) with short bolts (1), lock washers (3), flat washers (5) and metal bracket (7). Tighten all bolts by wrench (8).

Step 4: Turn the table upright. Place the baskets (E) on the shelf (B) as shown.

Assembly is now complete.



Hardware Pack (F)

1	Short Bolt		1/4"x5/8"	12 pcs
2	Long Bolt		5/16"x2"	6 pcs
3	Lock Washer		1/4"	12 pcs
4	Lock Washer		5/16"	6 pcs
5	Flat Washer		1/4"	12 pcs
6	Flat Washer		5/16"	6 pcs
7	Metal Bracket		30x20mm	6 pcs
8	Wrench		10-12mm	1 pc